

The AGI logo is located in the top right corner of the image. It consists of the letters "AGI" in a bold, white, sans-serif font, followed by a stylized white graphic element that resembles a wing or a series of curved lines.The text "AGI HI ROLLER" is positioned in the middle-left section of the image. It is written in a bold, white, sans-serif font. The "AGI" part is smaller and includes the stylized wing logo. The background behind this text is a semi-transparent green overlay of an industrial facility.The text "MINI & LO ROLLER" is located below the first line of text. It is written in a bold, white, sans-serif font. The background is the same semi-transparent green overlay of an industrial facility.The text "MODELS 18-72" is the final line of text in the middle-left section. It is written in a bold, white, sans-serif font. The background is the same semi-transparent green overlay of an industrial facility.

The Problem Solver

Invest in Efficiency

Hi Roller Enclosed Belt Conveyors are heavy duty, low maintenance, safe, gentle, and efficient. Hi Roller uses unique idlers which allow all bearings to be isolated from internal dust and contaminants. Internally, the troughing belt gently conveys bulk materials to the discharge point. The returning belt slides over an antistatic return liner and continually wipes the bottom enclosure clean of any dust or spilled material. The patented reloading system is the key to a successful system. The absence of this feature can cause product build up, plugging, costly wear, and downtime.

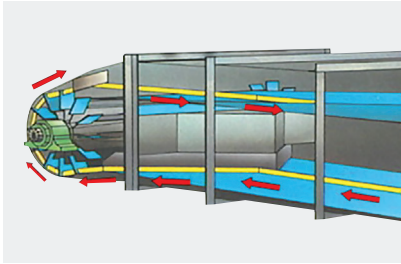

Hi Roller Enclosed Belt Conveyors are designed for the safe, gentle, and efficient handling of dry, bulk materials. This unique, totally enclosed belt conveyor contains dust and spilled material and automatically reloads that material back.

The arrow shows the flow of dust and spilled material back to the tail section where it is directed into reloading vanes, then thrown and deflected back on to the top belt.



The heavy duty tail section incorporates a gasketed sliding box take-up with tensioning and leveling rods. The tail shaft is supported by external pillow block spherical roller bearings. The tail shroud splits at the shaft so that the pulley can be removed without cutting the belt. The shroud comes complete with safety chains and can be removed without the use of tools.

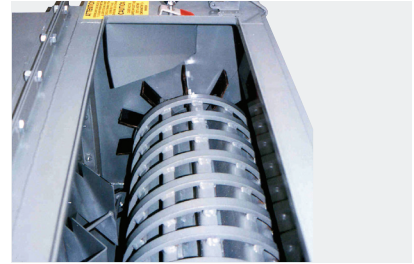

Internally, the spiral winged tail pulley provides constant belt contact for extended belt life. The patented reloading system includes a rugged plow, reloading flippers and a stationary deflector.



Mini Roller & Lo Roller



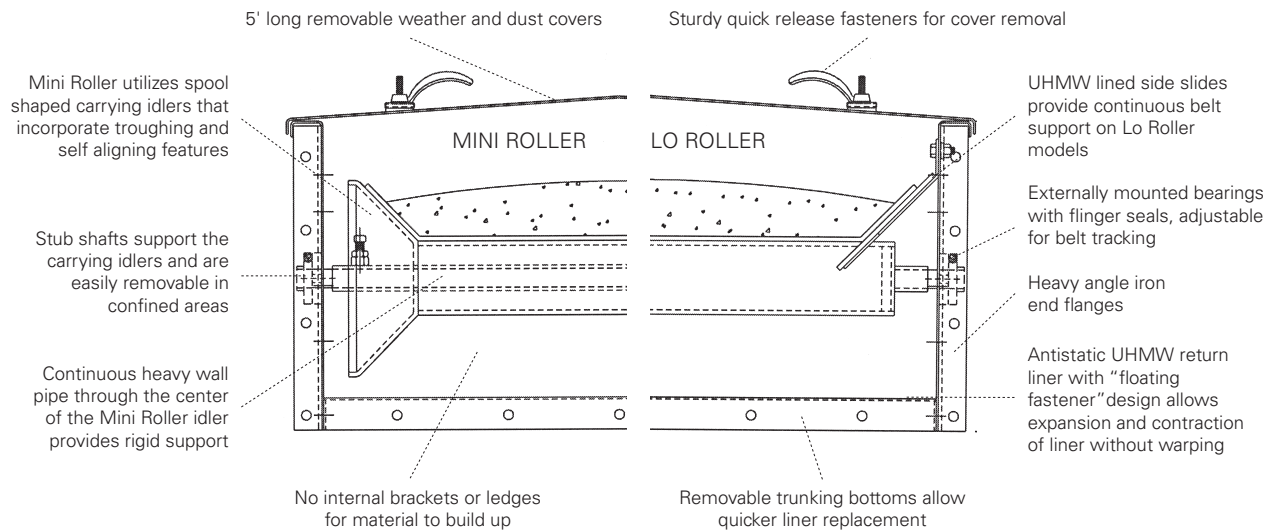

HI ROLLER CAPACITIES

MODEL	UNITS	BELT SPEED IN FEET PER MINUTE							
		350	400	450	500	550	600	650	700
16	BU/HR	2,489	2,485	3,200	3,556	3,911	4,267	4,263	4,978
	CF/HR	3,099	3,542	3,984	4,427	4,870	5,313	5,755	6,198
	MTPH	67	77	87	96	106	116	125	135
20	BU/HR	3,734	4,267	4,800	5,334	5,867	6,401	6,934	7,467
	CF/HR	4,648	5,313	5,977	6,641	7,305	7,969	8,633	9,297
	MTPH	101	116	130	145	159	173	188	202
24	BU/HR	5,088	5,815	6,542	7,269	7,996	8,722	188	10,176
	CF/HR	6,335	7,240	8,145	9,049	9,954	10,859	11,764	12,669
	MTPH	138	158	177	197	217	236	256	276
30	BU/HR	7,321	8,367	9,413	10,459	11,504	12,550	13,596	14,642
	CF/HR	9,115	10,417	11,719	13,021	14,323	15,625	16,927	18,229
	MTPH	198	227	255	283	312	340	368	397
36	BU/HR	9,795	11,195	12,594	13,993	15,393	16,792	18,192	19,591
	CF/HR	12,195	13,938	15,680	17,422	19,164	20,906	22,648	24,391
	MTPH	265	303	341	379	417	455	493	531

LO ROLLER CAPACITIES

MODEL	UNITS	BELT SPEED IN FEET PER MINUTE							
		350	400	450	500	550	600	650	700
16	BU/HR	1,984	2,267	2,551	2,834	3,118	3,401	3,685	3,968
	CF/HR	2,470	2,823	3,176	3,529	3,882	4,234	4,587	4,940
	MTPH	54	61	69	77	84	92	100	108
20	BU/HR	4,257	4,886	5,497	6,108	6,719	7,329	7,940	8,551
	CF/HR	5,323	6,083	6,844	7,604	8,365	9,125	9,885	10,646
	MTPH	116	132	149	166	182	199	215	232
24	BU/HR	5,969	6,509	7,323	8,137	8,950	9,764	10,578	11,391
	CF/HR	7,091	8,104	9,117	10,130	11,143	12,156	13,169	14,182
	MTPH	154	176	198	221	243	265	287	309
30	BU/HR	8,031	9,178	10,326	11,473	12,620	13,768	14,915	16,062
	CF/HR	9,999	11,427	12,855	14,284	15,712	17,141	18,569	19,997
	MTPH	218	249	280	311	342	373	404	435
36	BU/HR	10,615	12,132	13,648	15,165	16,681	18,191	19,714	21,231
	CF/HR	13,216	15,104	16,992	18,880	20,768	22,656	24,544	26,432
	MTPH	288	329	370	411	452	493	534	575

BU/HR Bushels Per Hour | **CF/HR** Cubic Feet Per Hour | **MTPH** Metric Ton Per Hour (Based upon 769 Kg Cubic Meter)
 Capacities are based upon horizontal installation and even belt loading.

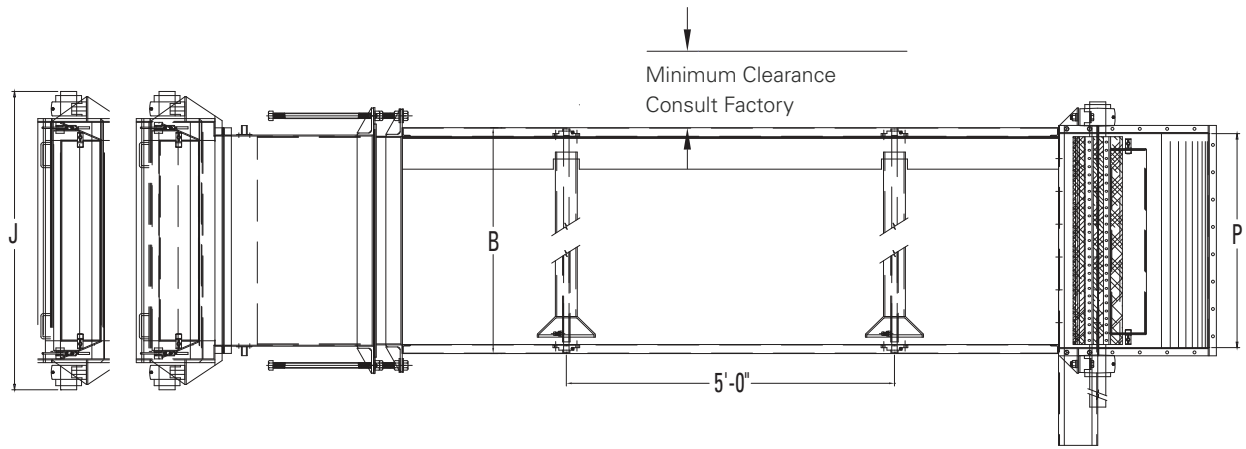

** Overall width determined by bearing and drive size.

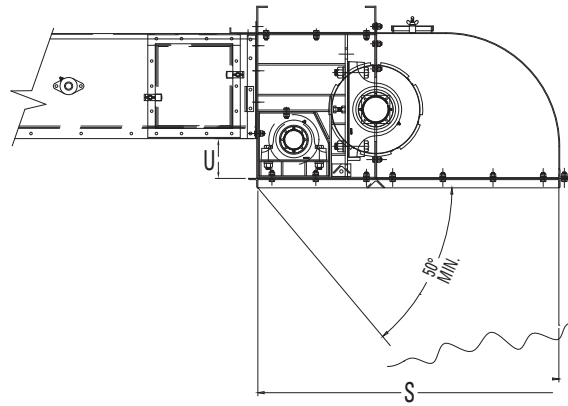
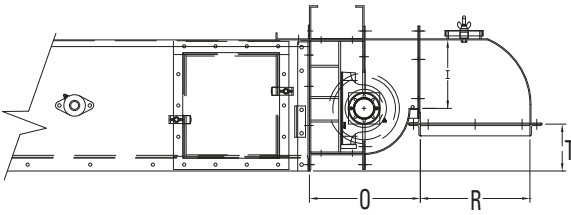
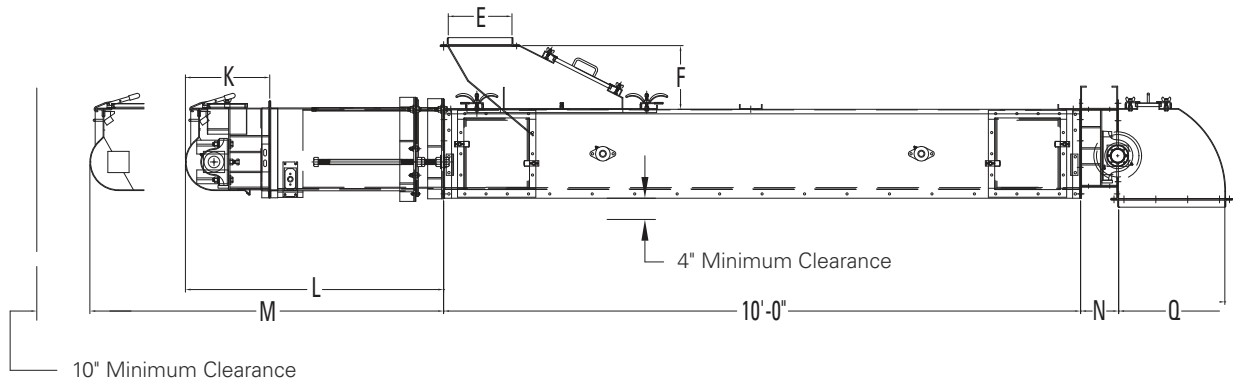

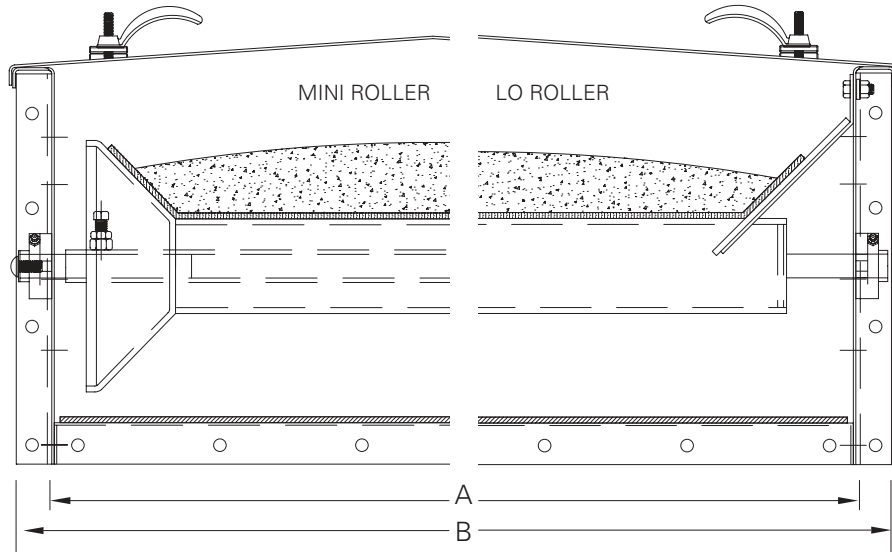

MINI & LO ROLLER DIMENSIONS

MINI & LO MODELS

DESCRIPTIONS	18	22	26	32	38
A Trunking Width (Inside)	18	22	26	32	38
B Trunking Width (Outside)	21 1/2	25 1/2	29 1/2	35 1/2	41 1/2
C Trunking Height (Outside)	16 3/4	16 3/4	16 3/4	16 3/4	16 3/4
D Inlet Opening Width	6	10	14	20	26
E Inlet Opening Length	12	12	12	12	12
F Standard Inlet Height	12	12	12	12	12
G Cleanout Inlet Height	1 5/8	1 5/8	1 5/8	1 5/8	1 5/8
H Inlet Cover Length	36	36	36	36	36
I Lo Profile Opening Height	8 3/4	8 3/4	8 3/4	8 3/4	8 3/4
J Tail Width (Less Bearings)	25 1/2	29 1/2	39 1/2	45 1/2	51 1/2
K Stub Tail Length	15 7/8	15 7/8	15 7/8	15 7/8	15 7/8
L Take-Up Length Retracted			Take-up Length + 24 5/8		
M Take-Up Length Extended			Take-up Length x 2 + 24 5/8		
N Std Head Length	7	7	7	7	7
O Lo Profile Head Length	14	14	14	14	14
P Discharge Opening Width	19 1/8	23 1/8	27 1/8	33 1/8	39 1/8
Q 90 Degree Discharge Length	20	20	20	20	20
R Lo Profile Discharge Length	14	14	14	14	14
S Snubber Discharge Length	48	48	48	48	48
T Discharge To Trunking Bottom	6	6	6	6	6
U Discharge To Trunking Bottom	3 3/8	3 3/8	3 3/8	3 3/8	3 3/8

The above dimensions are stated in inches. Designs and specifications are subject to change without notice. Hi Roller Conveyors are manufactured under several Patents and Pending Patents.



Inlet heights and lengths can be customized to your specific applications

The Mini Roller and Lo Roller conveyors provide you with two options for lower profile, lower capacity conveying. The unique spool shaped idler used in the Mini Roller provides a troughed support for the conveyor belt. The spool shaped idler uses two external bearings as opposed to six internal bearings on more conventional idlers. Alternatively, the Lo Roller utilizes flat idlers for belt load support and UHMW lined side slides for belt edge support. This design provides a continuous seal along the belt edge for the entire length of the conveyor. The Mini Roller idler is constructed with a heavy wall pipe that passes through the center of the idler. This provides rigid support. The center pipe is then reamed to just the right tolerance to accept the turned and polished stub shaft that passes through the external bearings.

The Lo Roller idler is constructed with an integral shaft as opposed to the stub shaft design. This idler can be removed by simply dropping the idler inside the enclosure and raising the belt edge to permit removal through the top of the conveyor.

FEATURES

- Gradual Inclines and Sharp Upbends
- Stationary Intermediate Discharge Trippers
- Moveable Discharge Trippers and Plows
- Reversible Conveyors (Reloading in Both Directions)
- Two-way Discharge Valves
- Proportioning Gates
- Worm Gear Reduction Manual Belt Tensioners
- Load Cells for Belt Tension Monitoring
- V-Wheel Tail Supports
- Shuttle Conveyors
- Split Trunking to Facilitate Belt Splicing
- Quick-Draw Idlers and Grease Tubes
- Floor Supports and Hanger Brackets
- Cut-outs for Belt Misalignment Sensors
- Motion and Plug Sensors
- Galvanized and Stainless Steel Construction
- Metric Components
- Intermediate Sidewall Inspection Doors

Hi Roller is more than a manufacturer. We can review your project on-site, make recommendations, prepare proposal drawings, and provide start-up assistance. We have found that a successful installation relies upon a clear understanding of the process, from the spouting and placement of the material on to the belt to the discharge and spouting out the other end. Put our design experience to work for you.

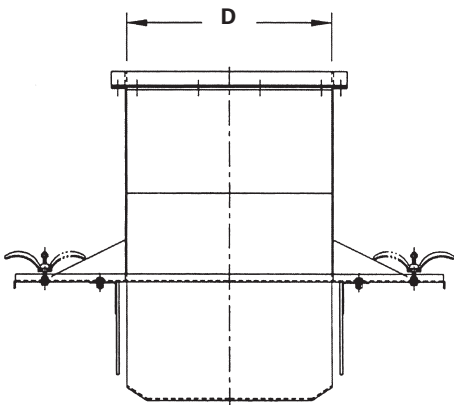

Above Typical initial inlet with fixed skirts

Below Typical cleanout inlet with swing-down skirts

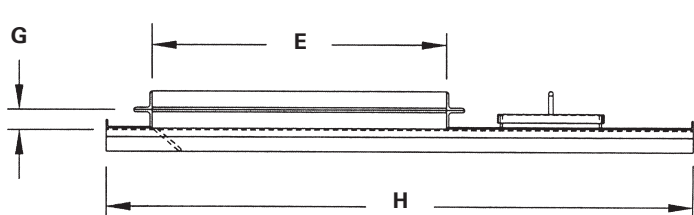
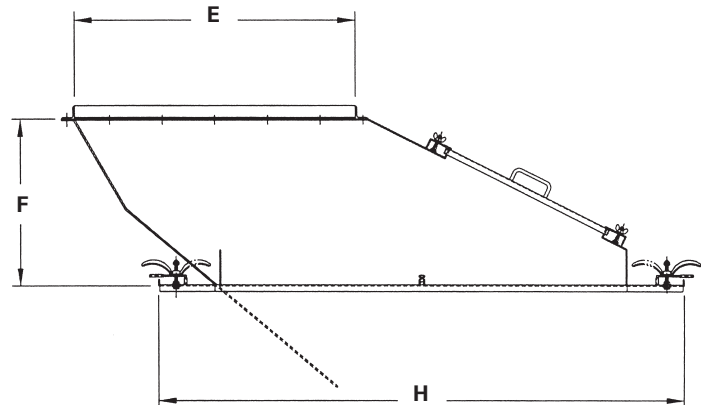
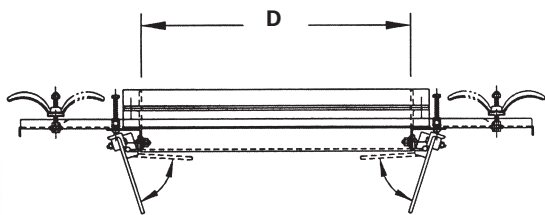

Installations



Product Line

Belt Conveyors have long been known as the most gentle, efficient and durable means of conveying materials.

AGI HI ROLLER Conveyors

are custom built to your specific requirements. Some of our more popular models include:

Hi Roller

Available in belt widths from 18" to 54", this is our original model. The unique bell-shaped carrying idler provides the trough for the belt and utilizes two external bearings as opposed to the six internal bearings associated with a conventional idler. The bell-shaped idler also has built-in self-aligning characteristics for both single and bi-directional conveyors.

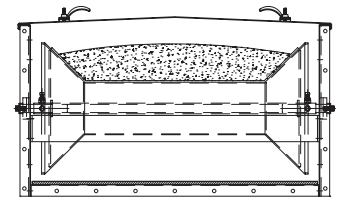

Hi Life

Available in belt widths from 18" to 72", the Hi Life utilizes possibly the heaviest, longest life, most reliable conveyor idler available. Resembling a conventional conveyor idler, the Hi Life idler is much thicker, the bearings are much larger, and there are no brackets or bearings exposed to the internal atmosphere of the conveyor housing.

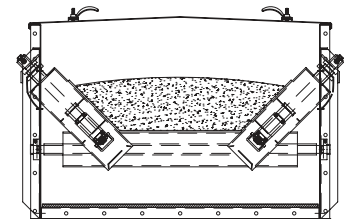

Mini Roller

Available in belt widths from 16" to 36", the Mini Roller includes all the benefits of the Hi Roller in a lower profile design. The bell shaped carrying idler, head, and tail pulleys all have a smaller diameter. This conveyor is well suited for low capacities.

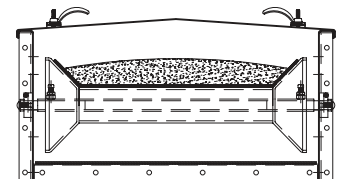

Lo Roller

Available in belt widths from 16" to 36", the Lo Roller utilizes a flat carrying idler to support the loaded weight of the belt and relies on the UHMW side slides to form a trough for the belt. The design provides continuous belt support and creates a seal at the edges.

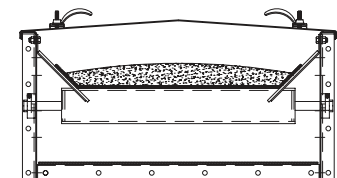

Hi Roller specializes in the custom design of enclosed belt conveyors to match your specific application. In addition to our standard models, we can also customize conveyors for your most unique applications. The Hi Bulk is an enmasse belt conveyor designed to move large quantities of material in a limited space. The Consignor is a belt conveyor with a totally enclosed, fully automated moveable discharge tripper. We look forward to helping you solve your most difficult material handling problems.



AGI is a global leader in supplying farm and commercial customers with the manufacturing, planning, and engineering of full equipment solutions for grain, seed, fertilizer, feed, and food. AGI's expertise enables the storage, blending, mixing, conveying, conditioning, processing, and protection of agricultural products and inputs worldwide.

Your safety is our highest priority.

Please read and understand the operator's manual and safety decals before using. Use and maintain products properly, and do not modify. Keep guards in place when operating and follow all product manuals and safety decals. For all AGI products, if guards, safety decals, or manuals are damaged or missing, contact your AGI sales or dealer representative for replacements. Images and information contained in this brochure are presented for general information.

AGI and the furrows symbol are trademarks belonging to Ag Growth International Inc.

198 Commerce Drive, Winnipeg, Manitoba, Canada R3P 0Z6

P 800.328.1785 | sales@hiroller.com | aggrowth.com/hiroller

     @aggrowthintl

AGGROWTH.COM